

CONVENTIONAL MOUNTING ASSEMBLY FOR BENDING BEAM LOAD CELLS

capacities 5kg - 500kg

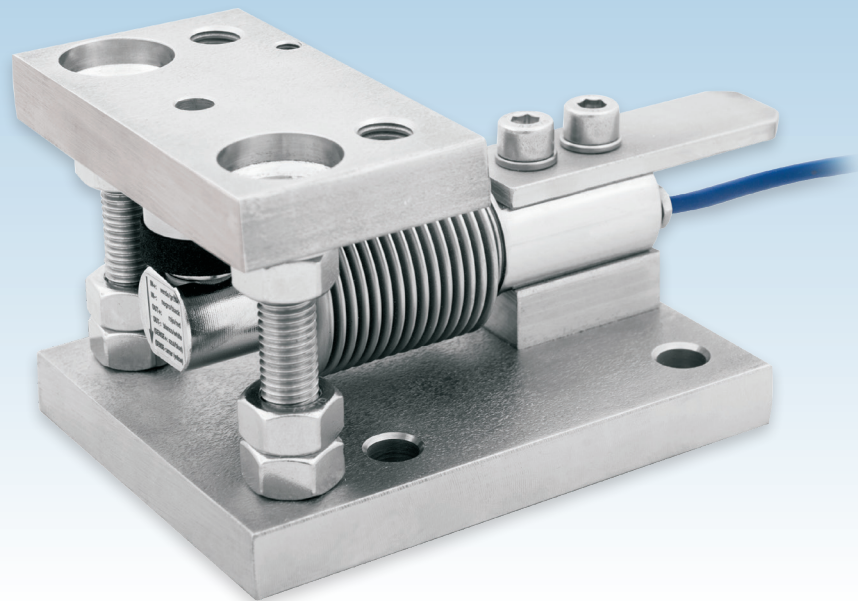

These load cell mounts are suitable for weighing platforms, bag fillers and tank weighing systems in the food processing, chemical, pharmaceutical & general bulk Handling industries.

The stainless steel, OIML C3 or C6 approved, model T66 load cell used in this anti-vibration weighing assembly is fully welded and hermetically sealed for protection to IP68 and IP69K, allowing it to be used in extremely harsh environments with exceptional accuracy.

ATEX certification, for both gas and dust zones, is available for the T66 load cell. To reduce costs, certification for use in dust zones 20, 21 and 22 without safety barriers is available.

For applications in aggressive environments where stress corrosion or acid attack is an issue, a special Parylene coating for the load cell can be specified as an option. Other options are custom load cell cable lengths for volume OEM customers and a version for high temperature use.

- Stainless steel load sensor & mounting accessory
- Hermetically sealed, fully welded construction
- Simple, fast installation
- Sealed to IP68 / IP69K
- 3000 divisions OIML R60 Class C (C3)
- 5 year warranty
- High Integrity cable entry
- 6 wire (with sense wires) option
- High durability Polyurethane load cell cable
- Options of  approval, OIML C6 approval, Parylene coating or High Temperature use

LA66

technical specification...

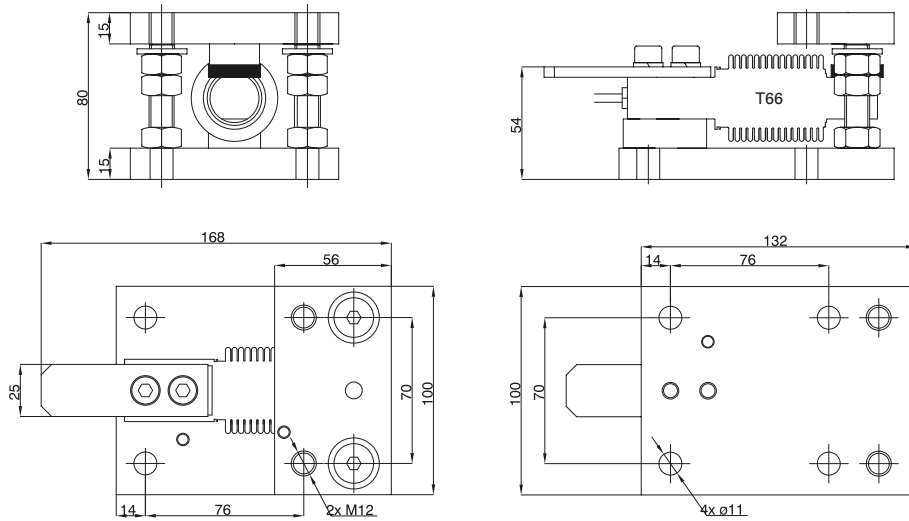

All dimensions in mm

T66 Load Cell

	Load cell specification		Units
	3000*	6000	n. OIML
Accuracy Class	3000*	6000	n. OIML
Load Cell Capacity (E_{max})	5, 10, 20, 30, 50, 100, 200, 300, 500	50, 75, 100, 150, 200, 250	kg
Rated Output (S_n)	2		mV/V \pm 0.1 %**
Combined Error	$< \pm 0.017$	$< \pm 0.008$	% S_n
Non-repeatability	$< \pm 0.015$	$< \pm 0.01$	% S_n
Minimum load cell verification interval (v_{min}) = E_{max} / Y	$E_{max} / 10000$	$E_{max} / 18000$	kg
Creep (30 minutes)	$< \pm 0.016$	$< \pm 0.008$	% S_n
Temperature Effect on Zero Balance	$< \pm 0.002$	$< \pm 0.001$	% $S_n / ^\circ C$
Temperature Effect on Span	$< \pm 0.0012$	$< \pm 0.0006$	% $S_n / ^\circ C$
Compensated Temperature Range	0 to +50		$^\circ C$
Operating Temperature Range	-30 to +70		$^\circ C$
Safe Overload	200		% E_{max}
Ultimate Overload	300		% E_{max}
Zero Balance	$< \pm 2$		% S_n
Input Resistance	400		$\Omega \pm 20$
Output Resistance	350		$\Omega \pm 3$
Insulation Resistance	> 5000		M Ω @ 100V
Recommended Supply Voltage	5-15		V
Maximum Supply Voltage	15		V
Environmental Protection	IP68 / IP69K		-
Maximum deflection at E_{max}	0.2-0.4		mm
Cable Length	3		m
Cable Material	Polyurethane		-
Nominal Shipping Weight (load cell and LA66)	3		kg

* OIML C3 (3000 division) approval from 10-300kg
 ** For 5-20kg capacity range, rated output (S_n) tolerance is ± 0.2 %

4 Wire Connection (C3 only)

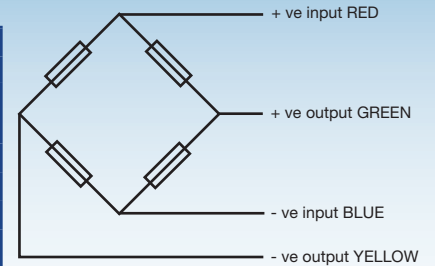

6 Wire Connection (C3 or C6)

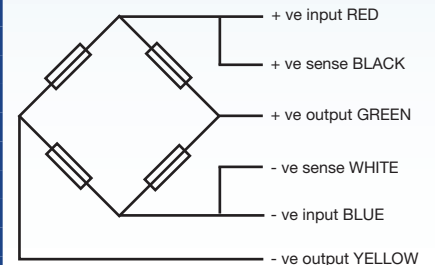

Electrical Connections

Via 4 or 6 wire, 5.7mm diameter, screened Polyurethane cable. OIML C6 version only available with 6 wire cable.
 Screen not connected electrically to load cell.

Construction

T66 load cell: stainless steel
 Mounting Assembly Acc. 30907: Nickel plated Alloy Steel
 Mounting Assembly Acc. 30907i: Stainless Steel

Thames Side Sensors India Pvt. Ltd.

A subsidiary of Thames Side Sensors Ltd. (UK)

C-6 & C-7, Hind Saurashtra Industrial Estate, Near Mittal Industrial Estate,
 Marol Naka, Andheri-Kurla Road, Andheri-East, Mumbai-400 059

T: +91 22 2850 6711

E:sales@thames-side.in

www.thames-side.in

CIN U31908MH2011FTC219481



Issue: IN/LA66.10.17

Our policy is one of continuous product enhancement. We therefore reserve the right to incorporate technical modifications without prior notification.



www.thames-side.in